



ETA-Danmark A/S
Göteborg Plads 1
DK-2150 Nordhavn
Tel. +45 72 24 59 00
Fax +45 72 24 59 04
Internet www.etadanmark.dk

Authorised and notified according
to Article 29 of the Regulation (EU)
No 305/2011 of the European
Parliament and of the Council of 9
March 2011

MEMBER OF EOTA



European Technical Assessment ETA-20/1072 of 2020/12/20

I General Part

Technical Assessment Body issuing the ETA and designated according to Article 29 of the Regulation (EU) No 305/2011: ETA-Danmark A/S

Trade name of the construction product:

Simpson Strong-Tie truss Hanger Types:
ET, ETC, MTHM, MTHM-2, THJA26, THG and THGQ.

Product family to which the above construction product belongs:

Three-dimensional nailing plate

Manufacturer:

SIMPSON STRONG-TIE Int. Ltd
For local branch refer to www.strongtie.eu

Manufacturing plant:

SIMPSON STRONG-TIE Manufacturing facilities

This European Technical Assessment contains:

33 pages including 4 annexes which form an integral part of the document

This European Technical Assessment is issued in accordance with Regulation (EU) No 305/2011, on the basis of:

EAD 130186-00-0603 for Three-dimensional nailing plates

This version replaces:

Translations of this European Technical Assessment in other languages shall fully correspond to the original issued document and should be identified as such.

Communication of the European Technical Assessment, including transmission by electronic means, shall be in full (except for any confidential Annexes referred to above). However a partial reproduction may be made with the written consent of the issuing Technical Assessment Body. Any partial reproduction has to be identified as such.

1 Technical Description of the Product

Simpson Strong-Tie ET, ETC, MTHM, MTHM-2, THJA26, THG and THGQ joist hangers (three-dimensional nailing plates) are one-piece, non-welded timber to timber joist hangers. They are connected to a header to support a joist with a range of nails, screws and bolts.

Headers and joists can be made of solid timber, glued laminated timber or engineered timber products such as LVL or LSL for instance. The header can also be made of concrete for ET and ETC hangers.

2 Specification of the Intended Use in Accordance with the Applicable European Assessment Document (EAD)

The hangers are made from zinc-coated steel and are available in a range of sizes (see Annex A). They are intended for use in making structural joints in timber structures, as a connection between a solid timber or wood-based joist and a solid timber or wood-based header, where Basic Works Requirement 1: Mechanical Resistance and Stability (CPR, Annex 1) applies. Headers can also be made of concrete or steel for ET and ETC hangers but load bearing capacities given in this ETA does not cover this particular case.

The hangers are for use in timber structures subject to the dry, internal conditions defined by Service Classes 1 and 2 of EN 1995-1-1 (Eurocode 5).

The range of hangers within this ETA is detailed in Annex A and B. Nailing patterns are in Annex C and the characteristic load bearing capacities are in Annex D.

The hangers shall be installed in accordance with instructions in Clause 2.4.2 and Annexes B to D.

The provisions made in this ETA are based on an assumed intended working life for the three-dimensional nailing plate of 50 years. The indications given on the working life cannot be interpreted as a guarantee given by the producer or by the Technical Assessment Body, but are to be used as a means for selecting the appropriate product in relation to the expected economically reasonable working life of the works.

3 Performance of the Product and References to the Methods used for its Assessment

BWR	Characteristic	Assessment of Characteristic
1	Mechanical Resistance and Stability	See ETA Section 3.1.1
2	Safety in Case of Fire	See ETA Section 3.2
	Reaction to Fire	See ETA Section 3.2.1.1
-	General Aspects Related to the Performance of the Product	

3.1 Methods of Verification

3.1.1 Mechanical Resistance and Stability

The characteristic load-carrying capacities of the products can be found in Annex D. These characteristic capacities are for use with Eurocode 5 only. These values are based on the assumption that instructions in Clause 2.4.2 and Annexes B to D are followed. No performance has been determined in relation to the joint's stiffness properties.

No performance has been assessed in relation to ductility of a joint under cyclic testing. The contribution to the performance of structures in seismic zones, therefore, has not been assessed.

3.2 Safety in case of Fire

3.2.1.1 Reaction to Fire

The joist hangers and associated nails are made from steel classified as Euroclass A1 in accordance with Commission Delegated Regulation 2016/364, EN 13501-1 and EC decision 96/603/EC, amended by EC Decision 2000/605/EC.

3.3 General Aspects Related to the Performance of the Product

3.3.1 Durability

The hangers have been assessed as having satisfactory durability and serviceability when used in timber structures using the timber species (including timbers preserved with organic solvent, boron diffusion and related preservatives) described in Eurocode 5 and subject to the dry, internal conditions defined by service classes 1 and 2. Connectors manufactured from stainless steel can also be used in Service Class 3 as defined in EN 1995-1-1: 2004.

3.3.2 Manufacturing

Simpson Strong-Tie ET, ETC, MTHM, MTHM-2, TJHA26, THG and THGQ hangers are manufactured in accordance with the provisions of this European Technical Assessment using the manufacturing processes as identified in the inspection of the plant laid down in the technical documentation.

3.3.3 Specific aspects related to the performance

It is the responsibility of the manufacturer to ensure that the information on the specific installation conditions given in this ETA is supplied to those concerned. This information may be made by replicating the respective parts of this European Technical Assessment. In addition, all installation data shall be shown clearly on the package and/or on an instruction sheet, preferably using illustration(s).

The minimum information required is:

- Fastener specification
- Requirements for timber members
- Identification of the manufacturing batch.

3.3.4 Joints

A hanger (three-dimensional nailing plate) is deemed fit for its intended use provided:

- The hanger capacity is determined with the tables in Annex D.
- Joints are designed in accordance with Eurocode 5 and EAD 130186-00-0603 under the responsibility of an engineer experienced in timber structures
- Verifiable calculation, notes and drawings are prepared taking account of the loads to be resisted
- The requirements detailed in Section 2.1 of this ETA, relating to the timber members being joined are taken into account, e.g. lateral restraint, wane, etc
- Joints are designed for the specified fasteners and grade or type of joist and header
- The actual end bearing capacity of the joist to be used with the hanger is checked by the designer of the structure to ensure it is not less than the hanger capacity and, if necessary, a hanger with a larger end bearing capacity substituted to suit.
- The minimum edge distance to a loaded edge shall comply with the requirements of Eurocode 5. Assessment.

3.3.5 Provisions

The fitness for use of the joint can be assumed if the hanger is installed correctly in accordance with the following requirements:

- The execution of the connection shall be in accordance with approval holder's technical literature.
- Ensure header is of adequate size to take the specified nails.
- The hanger side and back flanges may have a slight splay from nesting within the packing.
- It is essential to hold the hanger square to the header before nailing.
- The joist is installed in hanger ensuring it is free from wane and the gap between the end of joist and header does not exceed 3 mm.
- The header is restrained against rotation before application of full loading.
- Load capacities in Annex D are based on installation without wane cuts. However, the wane cuts is allowed but they don't increase their capacities.
- As soon as a wood member is in contact with a side flange, all holes must be installed with the specified nails.
- For ETC and ET, it is compulsory to use the nail holes located on the hangers back.
- The hanger bottom must not be under the carrying member edge
- The wood members realized with 2 ply must be connected with bolts, SDS screws or others fasteners in accordance with EC5. The Simpson connectors not ensure the connection with the two members.
- THG hangers shall be connected to the truss vertical member only (see figures in Annex A).

4 Assessment and Verification of Constancy of Performance

4.1 AVCP System

According to Decision 97/638/EC¹, the System(s) of Assessment and Verification of Constancy of Performance (see Annex V of Regulation (EU) No. 305/2011, as amended) given below applies.

Product	Intended Use	AVCP System
Three-dimensional nailing plates (with fasteners specified)	For structural timber products	2+

5 Technical Details necessary for the Implementation of the AVCP System, as foreseen in the applicable EAD

Technical details necessary for the implementation of the AVCP system are laid down in the control plan deposited at ETA-Danmark prior to CE marking

Issued in Copenhagen on 2020-12-20 by

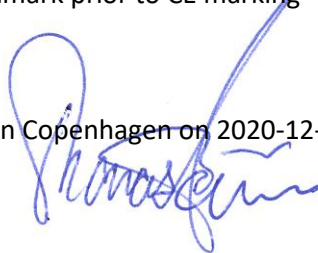

Thomas Bruun

Managing Director, ETA-Danmark

¹ COMMISSION DECISION of 9 March 1998 on the procedure for attesting the conformity of construction products pursuant to Article 20(2) of Council Directive 89/106/EEC as regards structural metallic products and ancillaries. Official Journal of the European Communities

Annex A: Product Details and Specification

Figure 1. ET Truss Hangers

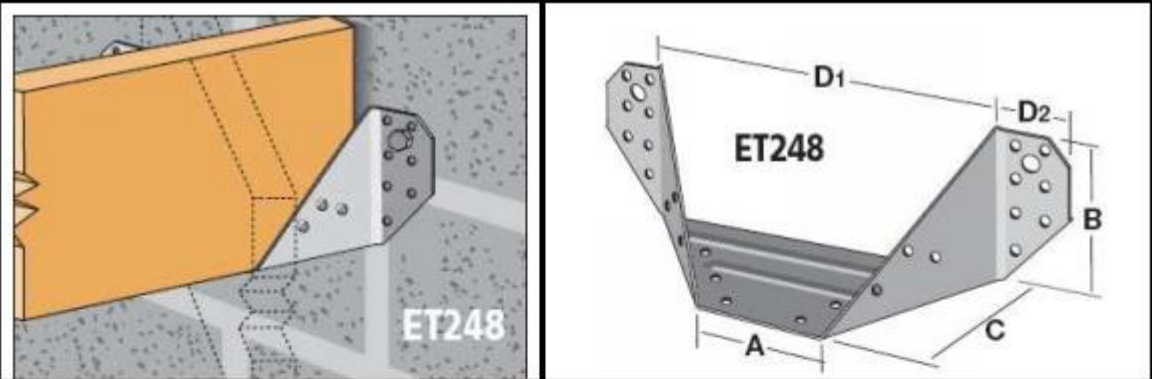

Figure 2. ET248 Truss Hanger

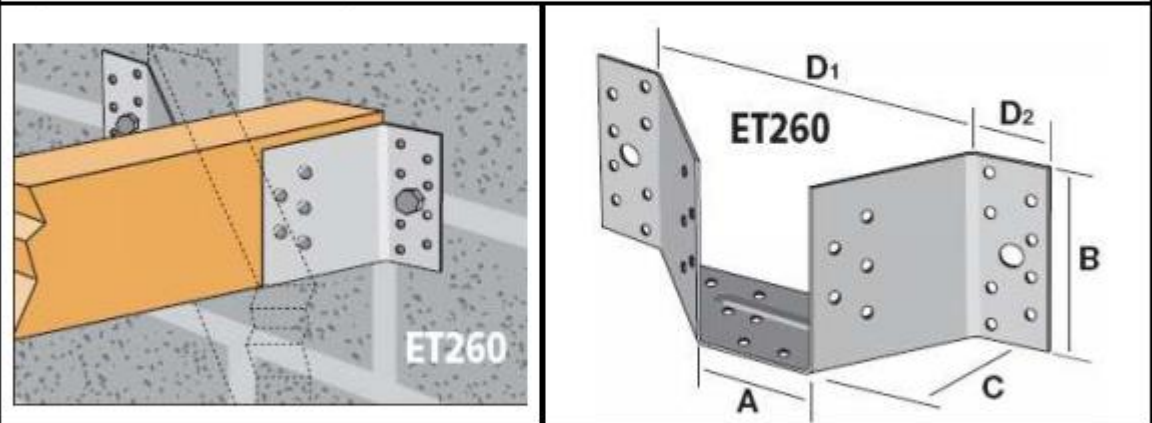

Table 1. ET260 Truss Hanger Specifications

Model No	Steel thickness (mm)	Steel specification and grade	Carried member	Dimensions (mm)				
				A	B	C	D1	D2
ET248	1.5	S250GD+Z275 to EN 10326-2004	1 plys 38	59.0	95.0	65	187.0	45
ET260			1 plys 47	66.5	96.5	55	176.5	34
ET301			1 plys 76 2 plys 38	107.5	96.5	55	217.6	34

Figure 3. ETC Truss Hangers

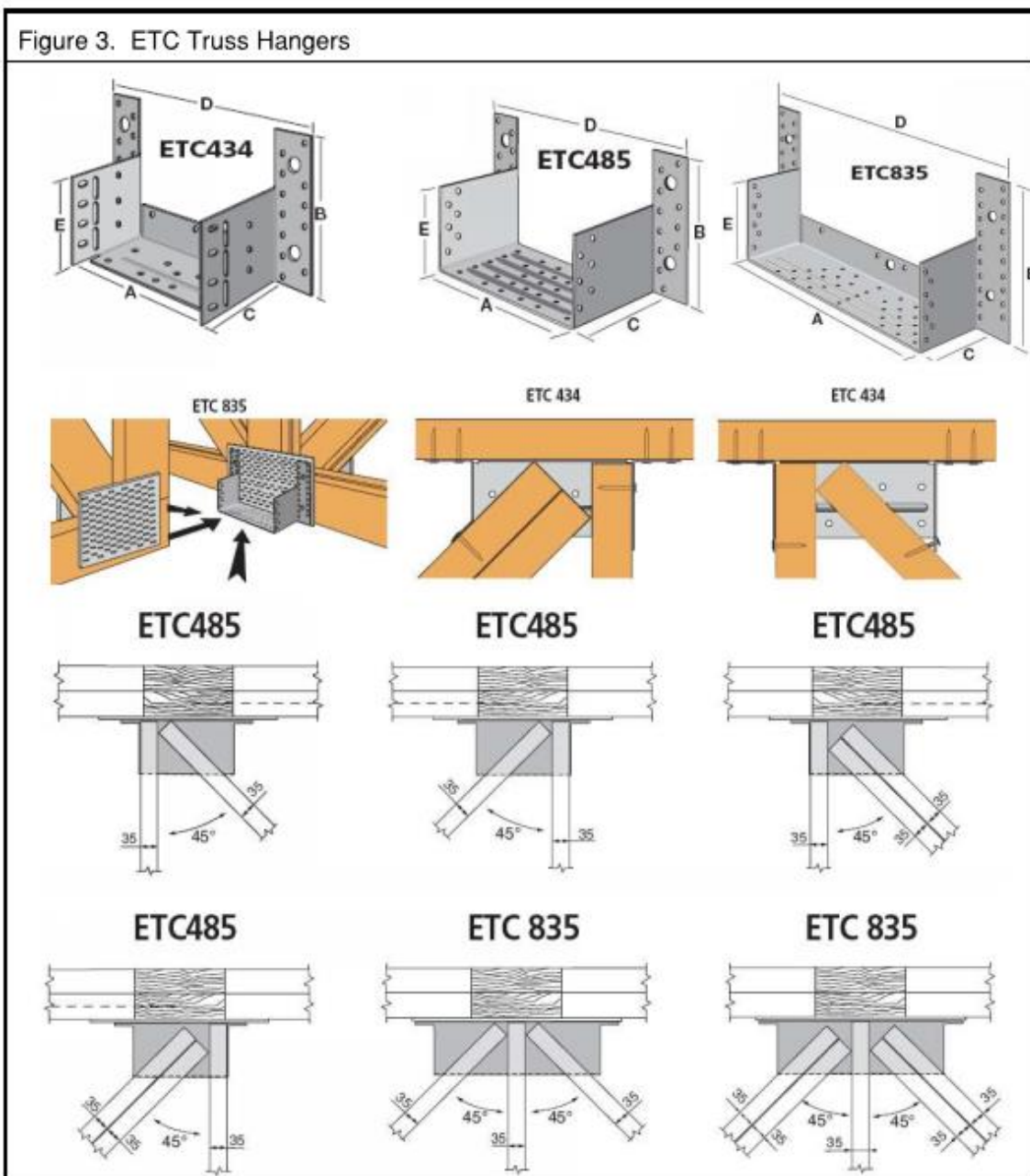
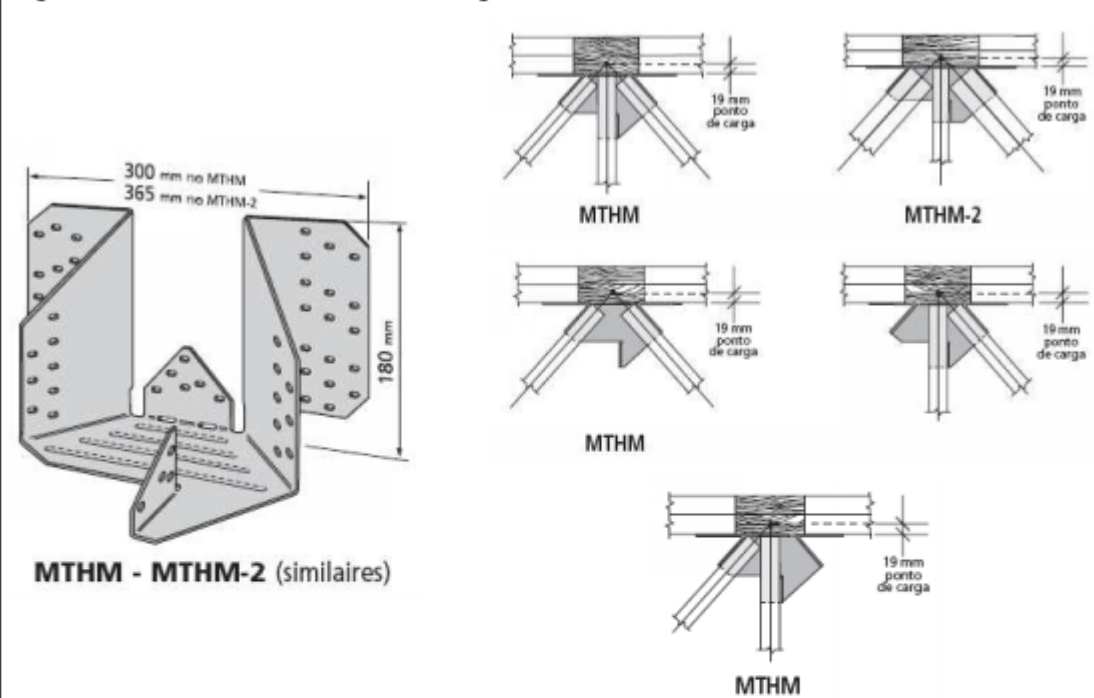

Table 2. ETC Truss Hangers Specifications

Model No	Steel thickness (mm)	Steel specification and grade	Carried member	Dimensions (mm)				
				A	B	C	D	E
ETC434	1.5	S250GD+Z275 to EN 10326-2004	1 jack rafter 38 1 hip-rafter 38 or 1 jack rafter 38 1 hip rafter 2x38	140	145	80	225	100
ETC485	2.0	Pre-galvanised steel G90 SS Grade 33 to ASTM A653	1 jack-rafter 38 1 hip-rafter 2x38	195	145	110	279	90
ETC835	3.0		1 jack-rafter 38 2 hip-rafter 38 or 1 jack-rafter 38 2 hip-rafter 2x38	355	240	110	481	140

Figure 4. MTHM / MTHM-2 Truss Hangers



MTHM - MTHM-2 (similaires)

Table 3. MTHM / MTHM-2 Truss Hangers Specifications

Model No	Steel thickness (mm)	Steel specification and grade	Carried member	Dimensions (mm)		
				Width	Height	Depth
MTHM	2.5	S250GD+Z275 to EN 10326-2004	1 jack-rafter 38 1 hip-rafter 38 or 2 hip-rafters 38	300	180	145
MTHM-2	2.5	Or Pre-galvanised steel G90 SS Grade 33 to ASTM A653	1 jack rafter 38 1 hip-rafter 2x38 or 1 jack rafter 38 2 hip-rafter 2x38	365	180	169

Figure 5. THG Truss Hangers

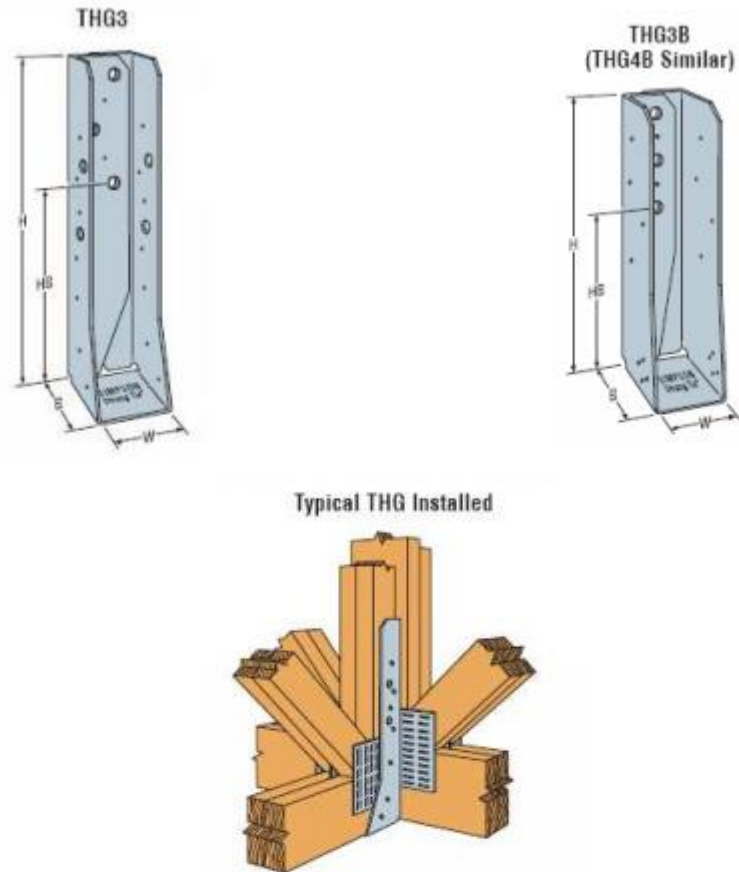

Table 4. THG truss Hangers Specifications

Model No	Steel thickness (mm)	Steel specification and grade	Carried member	Dimensions (mm)					
				W	H	B	HB		
THG2/80	3	DX51D+Z275 to EN 10327-2004	2 plys 35	80	475	115	317		
THG3/80					555	135	319		
THG3B/80					485	120	290		
THG4B/80					565	135	290		
THG2/105			2 plys 47	105	2 plys 47	105	475	115	217
THG3/105							555	135	319
THG3B/105							485	120	290
THG4B/105							565	135	290
THG3/120			3 plys 35	120	3 plys 35	120	555	115	319
THG3B/120							485	135	290
THG4/120							705	120	367
THG4B/120							565	135	290
THG3/155			3 plys 47	155	3 plys 47	155	555	115	319
THG3B/155							485	135	290
THG4/155							705	120	367
THG4B/155							565	135	290
THG4/210			4 ply 47	210	4 ply 47	210	705	135	367

Figure 6. THJA26 Truss Hangers

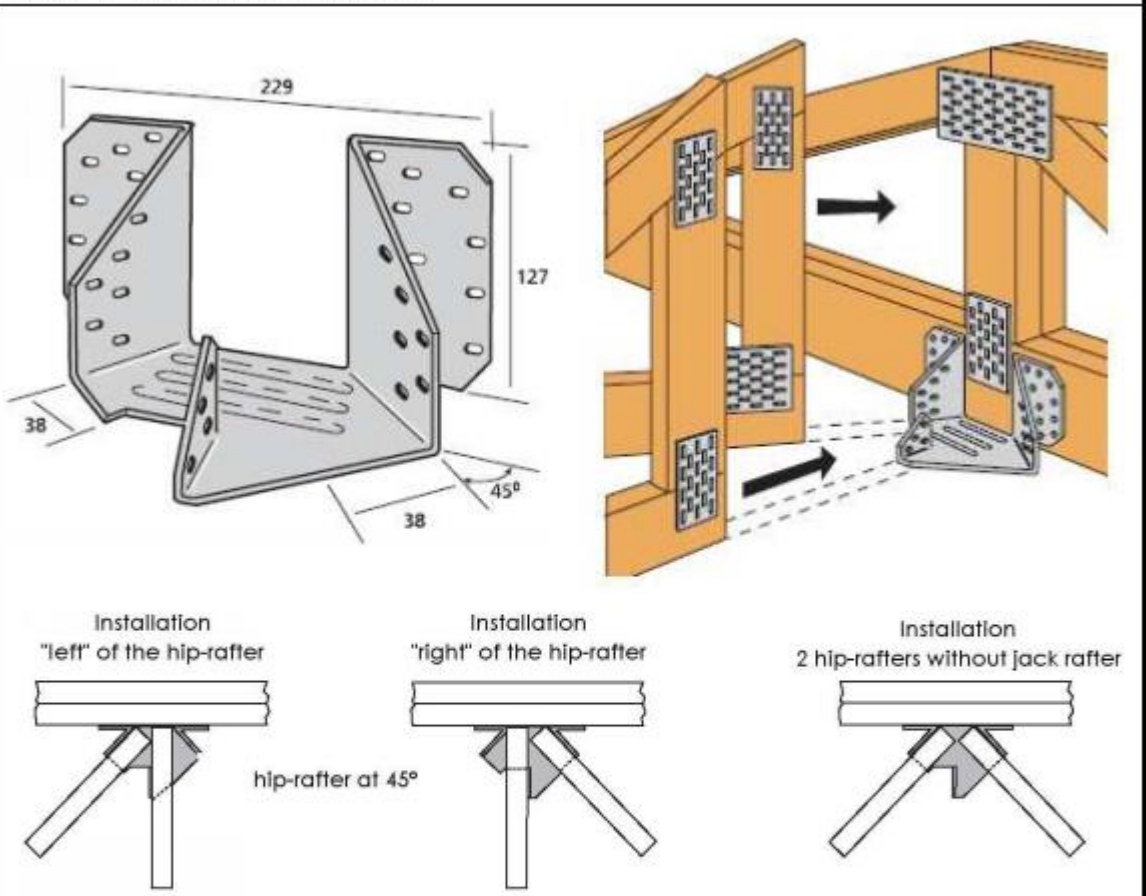

Table 5. THJA26 Truss Hangers Specifications

Model No	Steel thickness (mm)	Steel specification and grade	Carried member	Dimensions (mm)		
				Width	Height	Depth
THJA26	2.0	Pre-galvanised steel G90 SS Grade 33 to ASTM A653 Or S250GD+Z275 to EN 10326-2004	1 jack-rafter 38 1 hip-rafter 38 or 2 hip-rafter 38	229	127	145

Figure 7. THGQ Truss Hanger

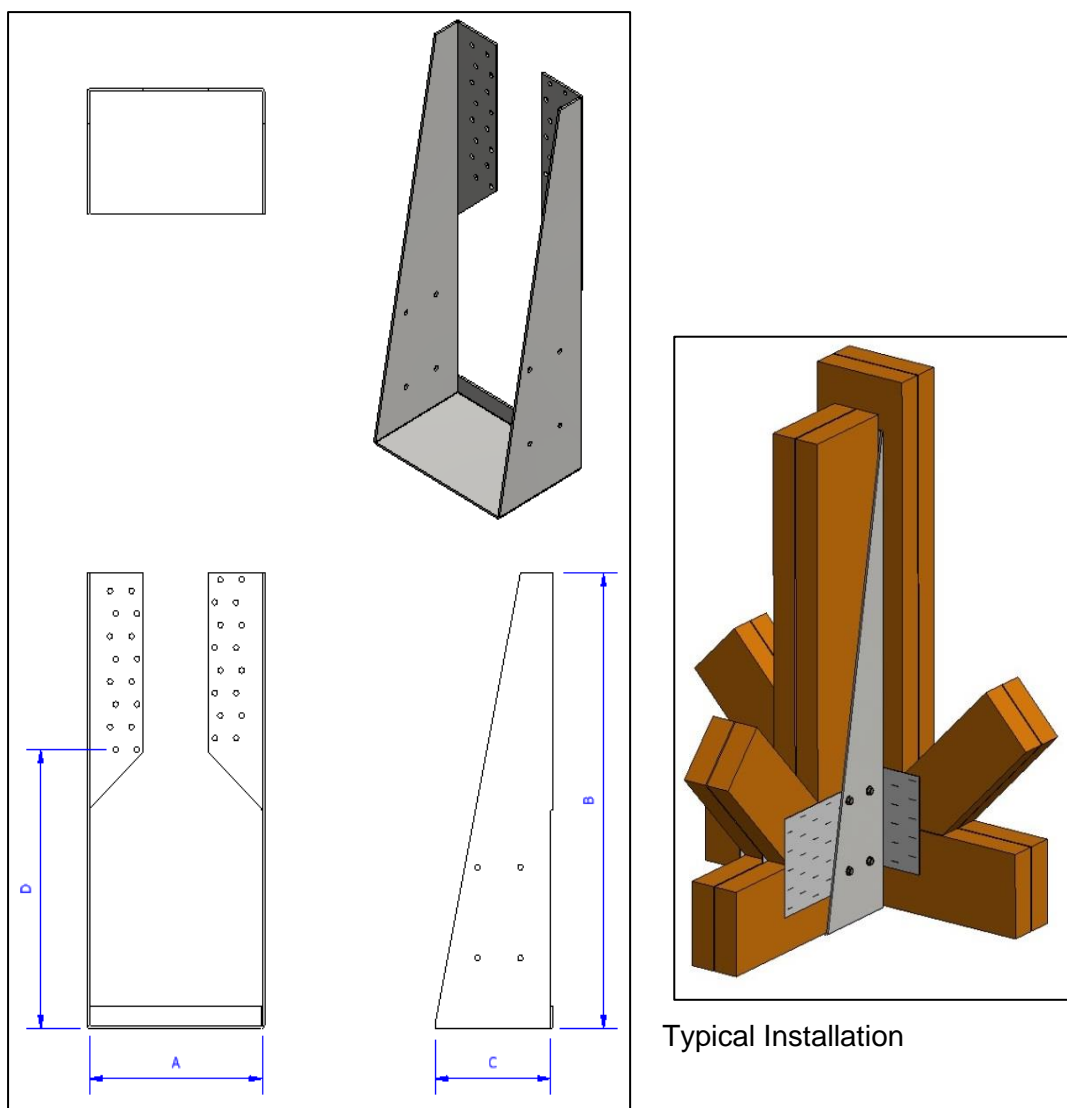

Table 6. THGQ Truss Hanger Specifications

Hanger	Supported member	Min width of vertical supporting member	Dimensions [mm]				
			A	B	C	D	t
THGQ80	2 ply 35	147	80	675	135	305	3.0
THGQ102	2 ply 47	172	102	675	135	305	3.0
THGQ116	3 ply 35	197	116	675	135	305	3.0
THGQ154	2 ply 47 or 4 ply 35	197	154	500	135	305	3.0
THGQ202	4 ply 47	222	202	500	135	305	3.0
Steel specification and grade		Pre-galvanized steel					

	Grade S250 or DX51D + Z (min Z275) according to EN 10346
--	--

Annex B: Fasteners

B1: Range of Fastener

Hanger capacities have been determined for the following range of header and joist fastener types.

Table 6: Nail Types

Diameter (mm)	Length (mm) Min - Max	Fastener Type
4.0	35 – 50	ETA nails according to ETA-04/0013
4.2	35 – 50	
3.75	75	Smooth Shank (SS) nail CE marked to EN 14592

Table 7: Screw Types

Diameter (mm)	Length (mm) Min - Max	Fastener Type
5.0	35 - 40	ETA screws according to ETA-04/0013
6.35	63	For THGQ Truss hangers: SDS25212 (63mm) SDS screws CE marked to EN 14592

Table 8: Bolt Types

Diameter (mm)	
20.0	Reference is made to the manufacturer specification for installation and load capacities in accordance to relevant ETA's or Eurocode 5.
24.0	

The load bearing capacities of the truss connectors have been determined based on the use of Simpson Strong-Tie connector nails Ø4.0 x 35 mm (ring shank nails). The properties of the nails have been derived in accordance with ETA-04/0013. It is allowed to use Simpson Strong-Tie connector screws according to ETA-04/0013 with the same or better performance as the nails and still achieve the same load-bearing capacity of the connection.

The design model also allows the use of threaded nails in accordance with EN 14592 with a minimum withdrawal parameter of 6 N/mm² and with a minimum ratio between the threaded length and the total length of 0.54, assuming a thick steel plate when calculating the nail lateral load-bearing capacity. If no calculations are carried out a reduction factor equal to the ratio between the characteristic withdrawal capacity of the actual used threaded nail and the characteristic withdrawal capacity of the corresponding Simpson Strong-Tie connector nail according to table B1 in ETA-04/0013 is applicable for all load bearing capacities of the connection.

Note: For THG hangers, the load capacities given in Annex D are based on typical applications. In some conditions, it is possible to increase these loads by using Bulldog connectors. These connectors are not included in the scope of this ETA and Simpson Strong-Tie should be contacted for more information.

B2 Mechanical Equivalence between Nail and Screw

For timber to timber connections, two types of fasteners are recommended:

- Connector Nails in accordance with ETA 04/0013 (CNA) Ø4.0 or Ø4.2
- Connector Screws in accordance with ETA 04/0013 (CSA) Ø5.0.

The determination of the load capacity is possible for both.

Table 9: Equivalence between Nail and Screw in accordance with ETA 04/0013

Length (mm)	
SST Connector Nails CNA Ø4.0 or Ø4.2	SST Connector Screws CSA Ø5.0
35 and 40	35
50	40
60, 75 and 100	50

The load capacities are based on the CNA nails Ø4.0 x 35 mm. Where Ø4.0 CNA nails are specific, Ø4.2 CNA nails may be used as an alternative.

B3 Fastener for Steel and Concrete Types

Hangers ET and ETC can be used with a concrete or steel carrying member. Specific fasteners must then be used:

- Mechanical anchor
- Chemical anchor
- Bolt
- Concrete screw

Reference is made to the manufacturer specification for installation and load capacities in accordance with relevant ETAs or Eurocode 3.

Fastener diameters are specified in Table 10.

Table 10: Correspondence between Truss Connectors and Fastener Diameter

Truss Connector (mm)	Fastener Diameter (mm)
ET	Ø10
ETC	Ø12
THG	Ø20
THG4B	Ø24

Annex C: Nailing Patterns

Fasteners other than CNA 4.0x35 mm nails may be used if instructions given in Annex B are followed.

Note that reference to ARS fasteners or Ring Shank Nails in the figures should be taken to mean CNA nails in accordance with ETA-04/0013 as described in Annex B.

C1 ET248 Hangers

Header

14 CNA nails $\varnothing 4.0 \times 35\text{mm}$

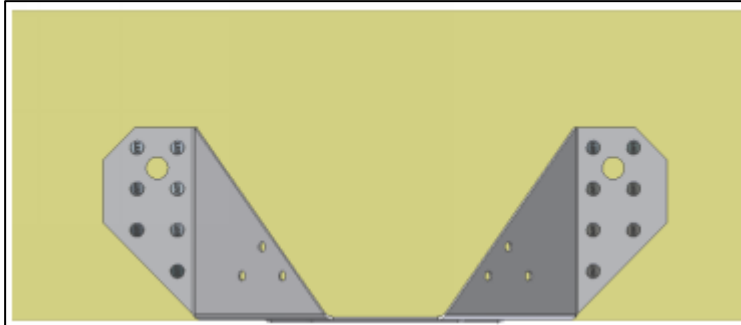

Bottom and Side Flange

3 CNA nails $\varnothing 4.0 \times 35\text{mm}$ on the bottom flange

3 CNA nails $\varnothing 4.0 \times 35\text{mm}$ on the side flange

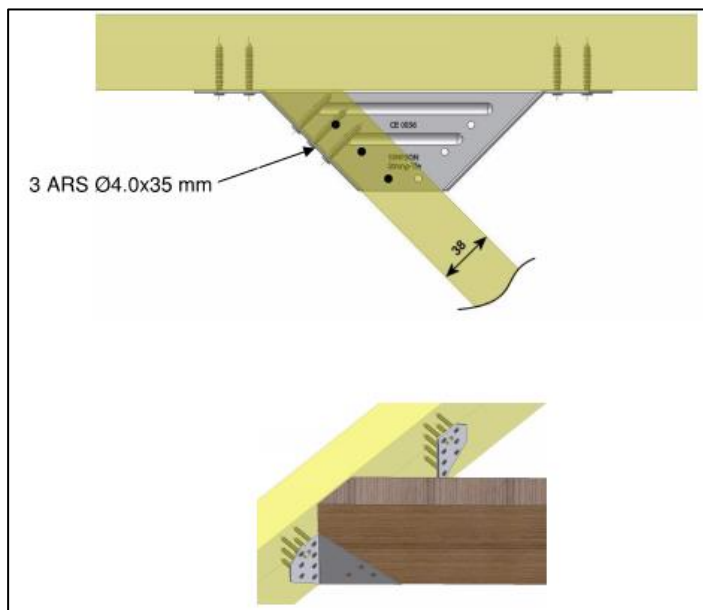

C2 ET260 Hangers

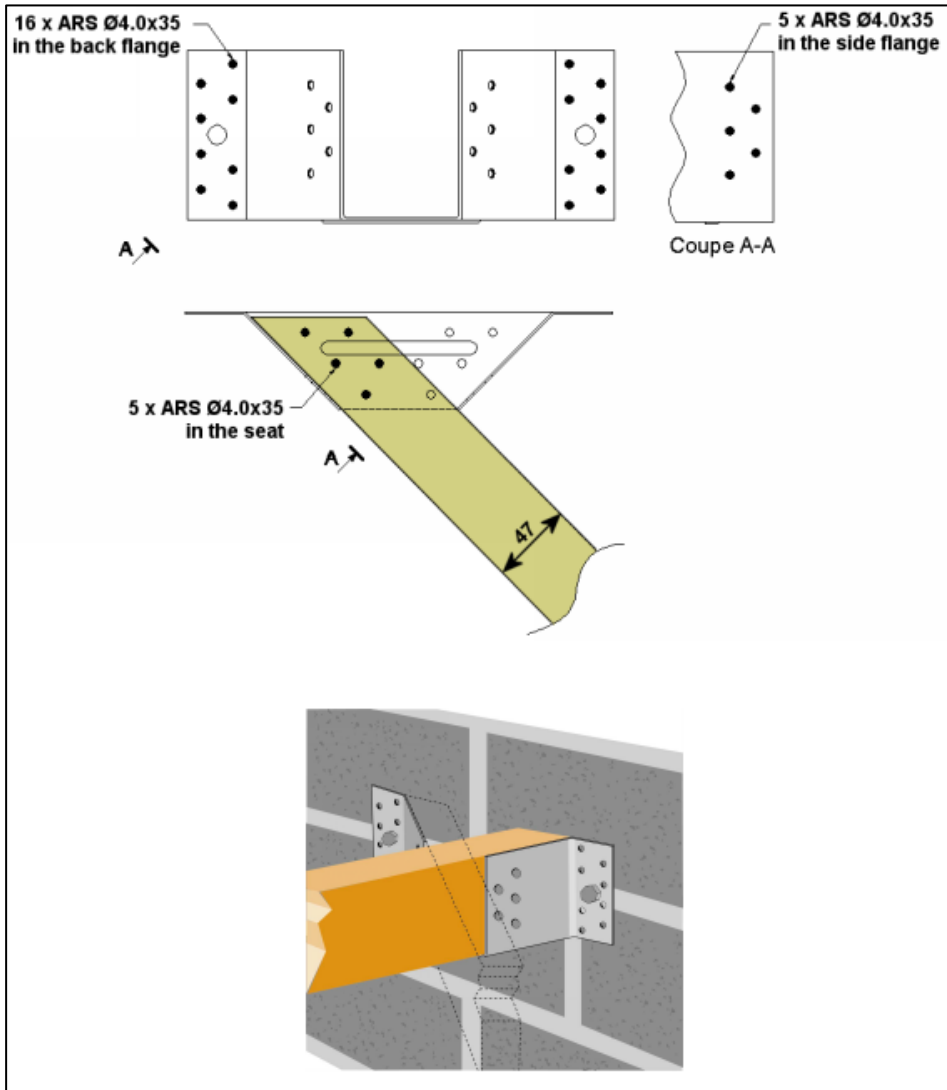

C3 ET301 Hangers

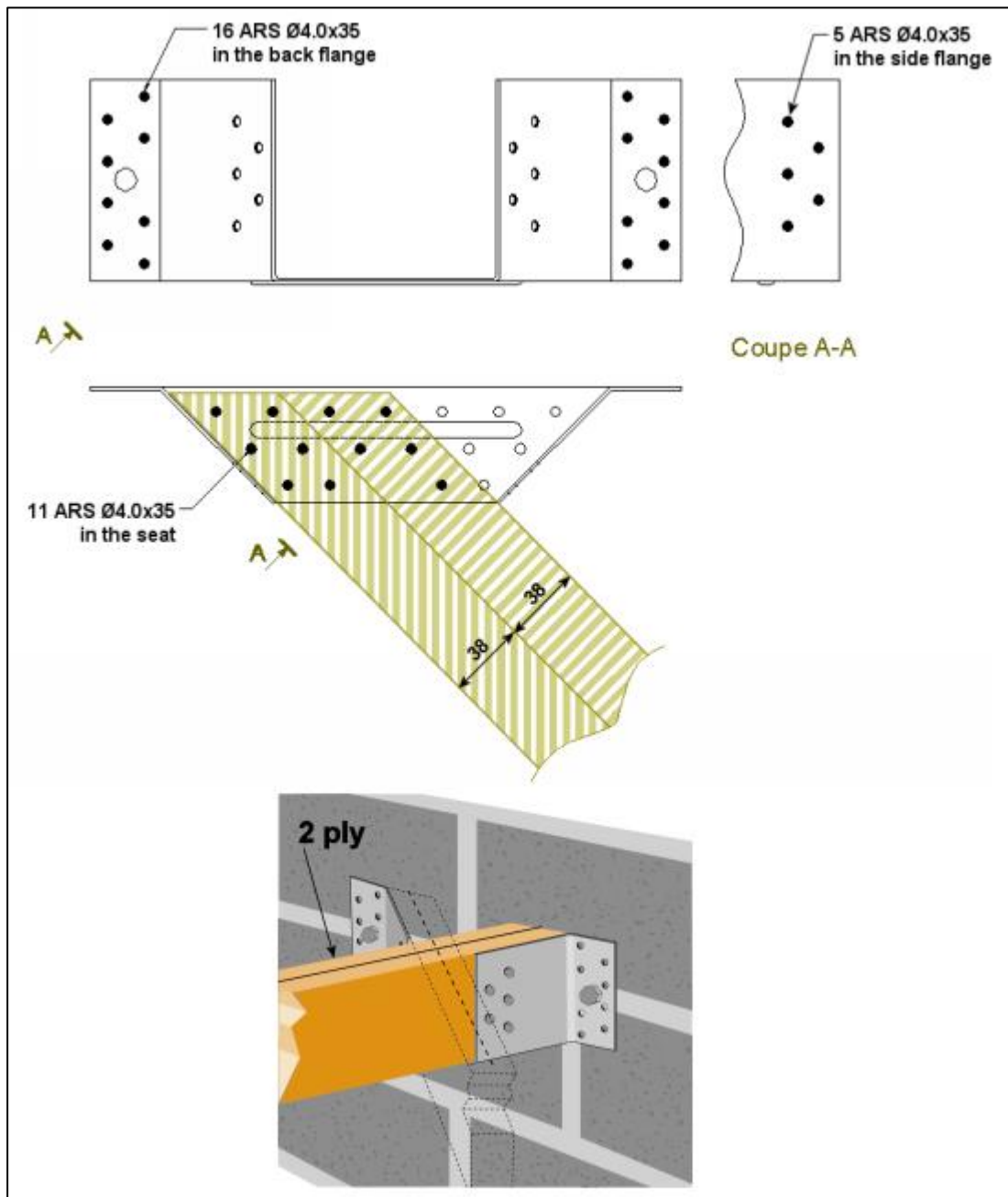

C4 ET Hangers - Nailing pattern for connection with timber elements with $h \geq 97\text{mm}$

Fastener specifications as above for the hanger type

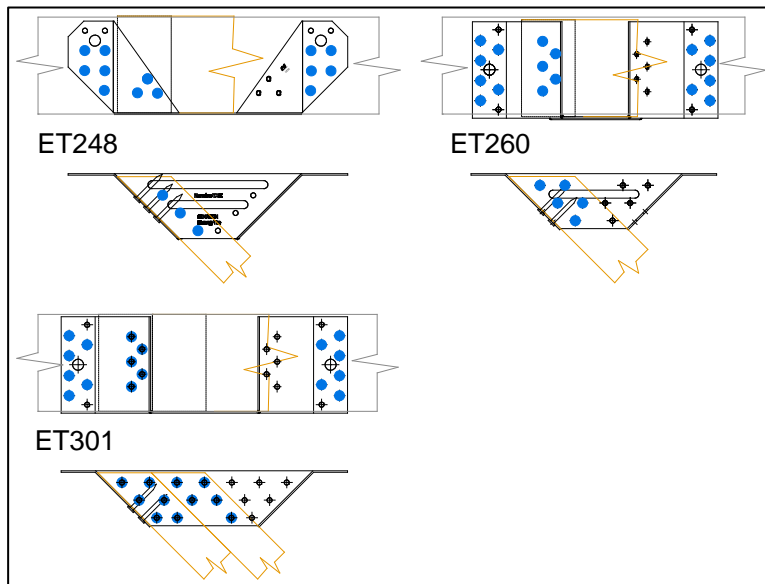

C5 ETC434 Hangers

Header

27 CNA nails $\varnothing 4.0 \times 35\text{mm}$

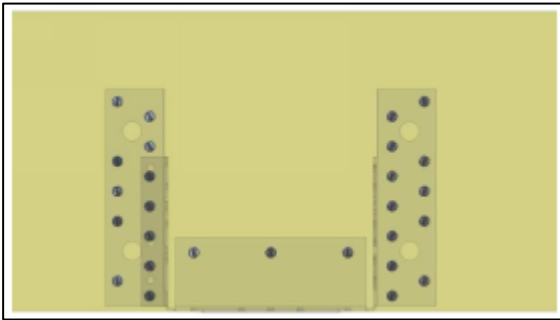

Simple Jack and Double Hips

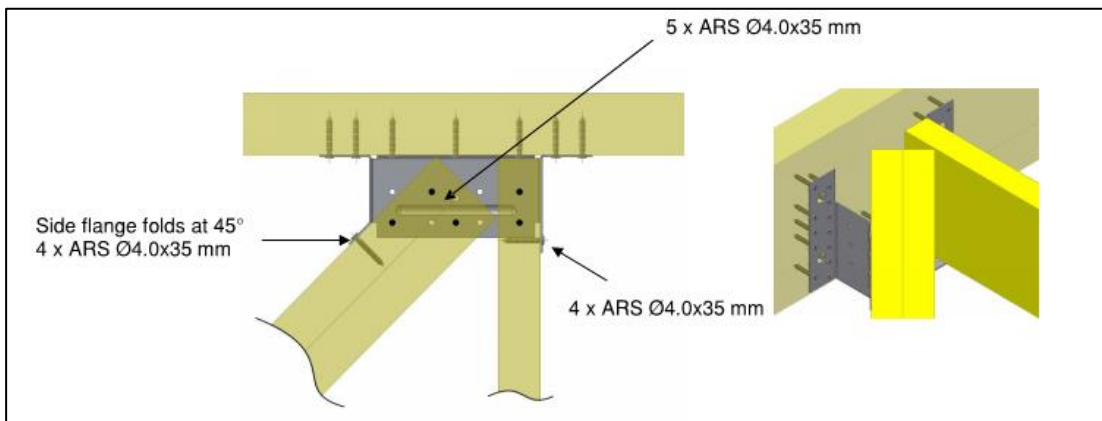

Simple Jack and Simple Hip

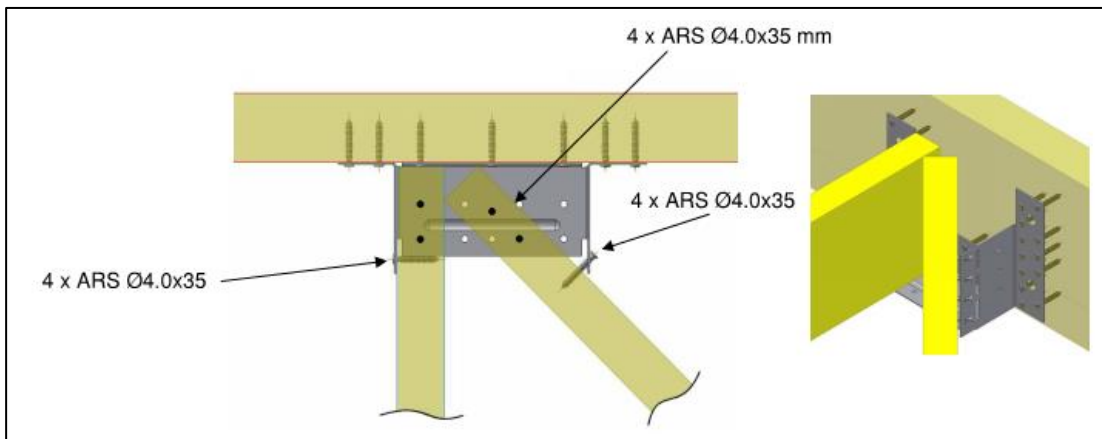

C6 ETC485 Hangers

Simple Jack and Double Hips

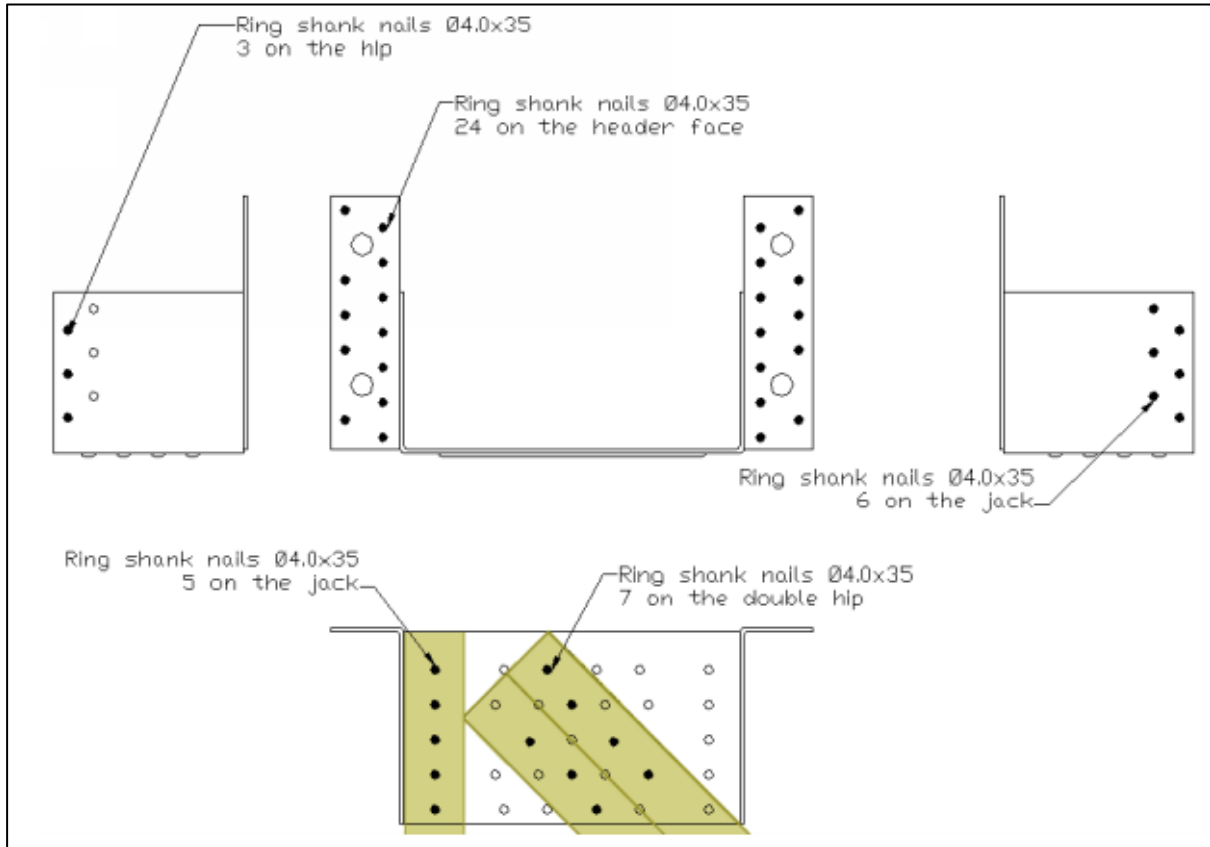

C7 ETC835 Hangers

Header

44 CNA nails $\varnothing 4.0 \times 35\text{mm}$

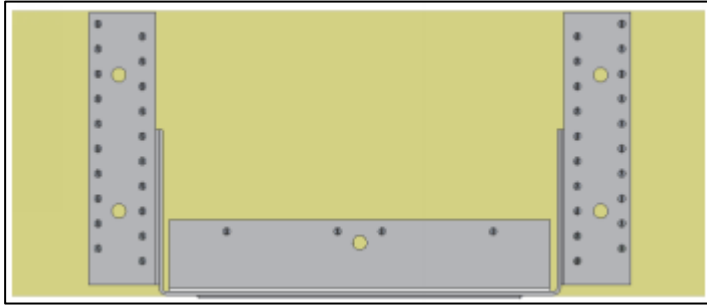

2 x Double Hip and Single Jack

Joist bottom: 19 CNA nails $\varnothing 4.0 \times 35\text{ mm}$

Joist side: 14 CNA nails $\varnothing 4.0 \times 35\text{ mm}$

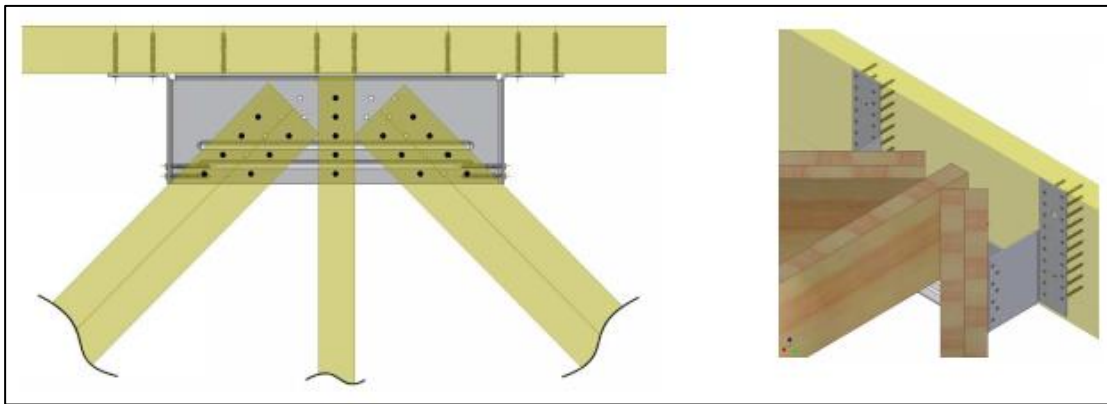

2 x Simple hip and single jack

Joist bottom: 15 CNA nails $\varnothing 4.0 \times 35\text{ mm}$

Joist side: 8 CNA nails $\varnothing 4.0 \times 35\text{ mm}$

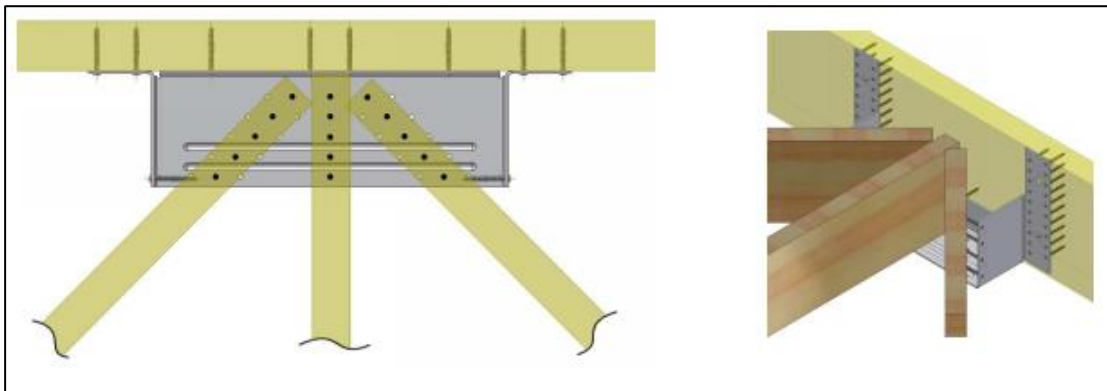

C8 MTHM Hangers

Header $\geq 147\text{mm}$

34 CNA nails $\varnothing 4.0 \times 35\text{mm}$

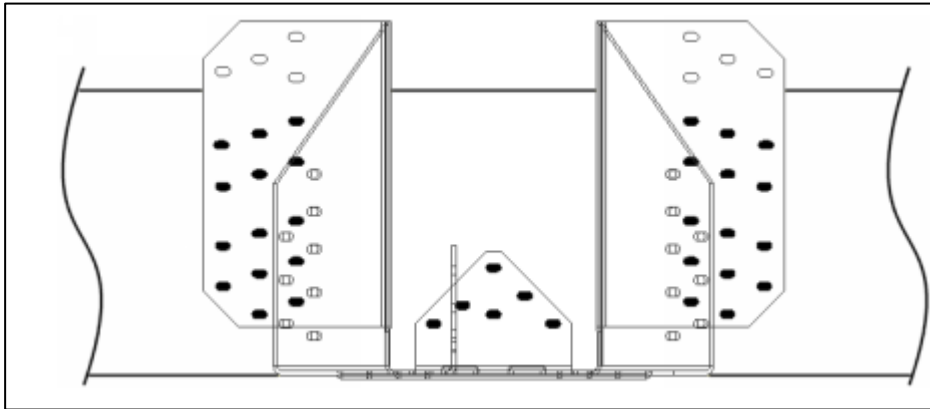

Header $\geq 222\text{mm}$

42 CNA nails $\varnothing 4.0 \times 35\text{mm}$

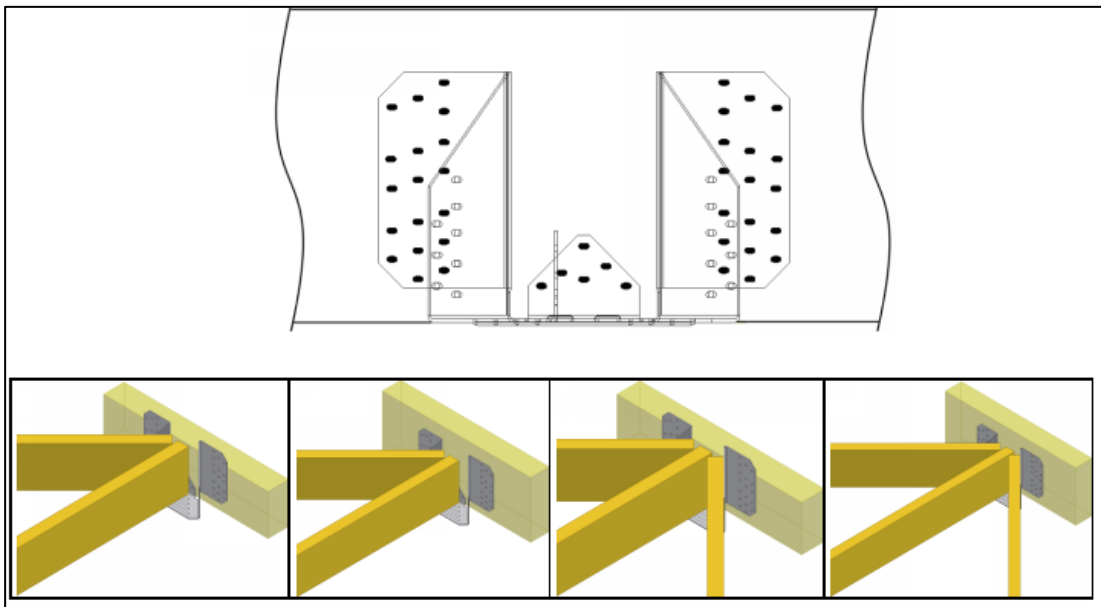

C9 MTHM-2 Hangers

Header $\geq 147\text{mm}$

39 CNA nails $\varnothing 4.0 \times 35\text{mm}$

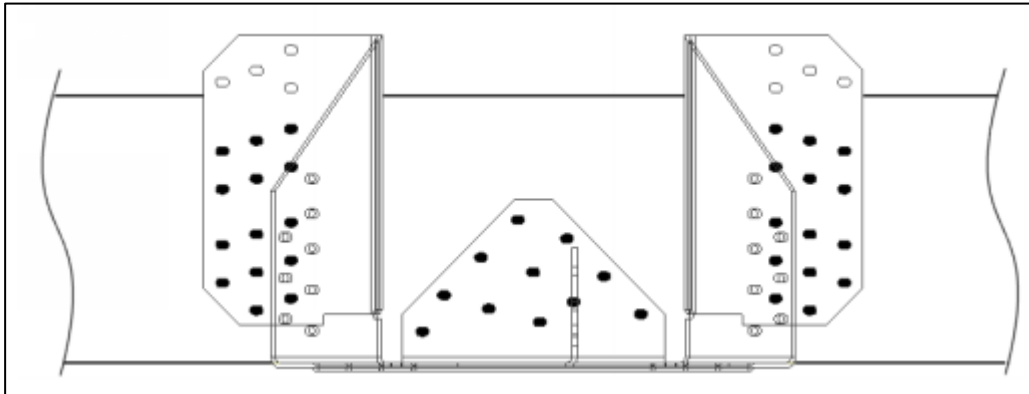

Header $\geq 222\text{mm}$

47 CNA nails $\varnothing 4.0 \times 35\text{mm}$

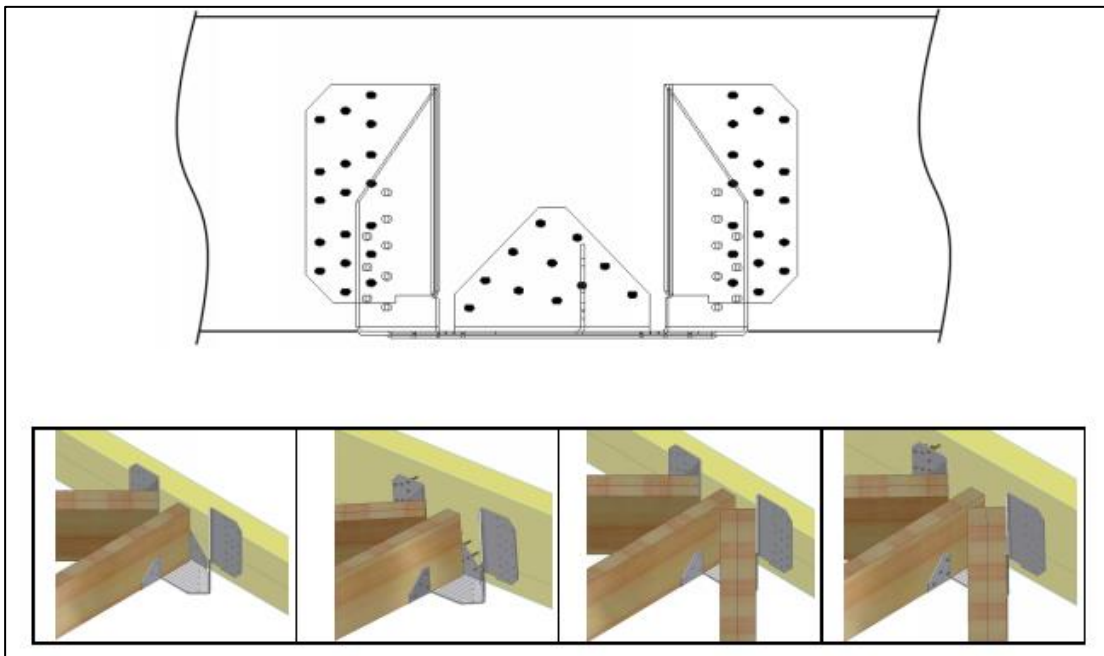

C10 THJA26 Hangers

Header

20 CNA nails $\varnothing 4.0 \times 35\text{mm}$

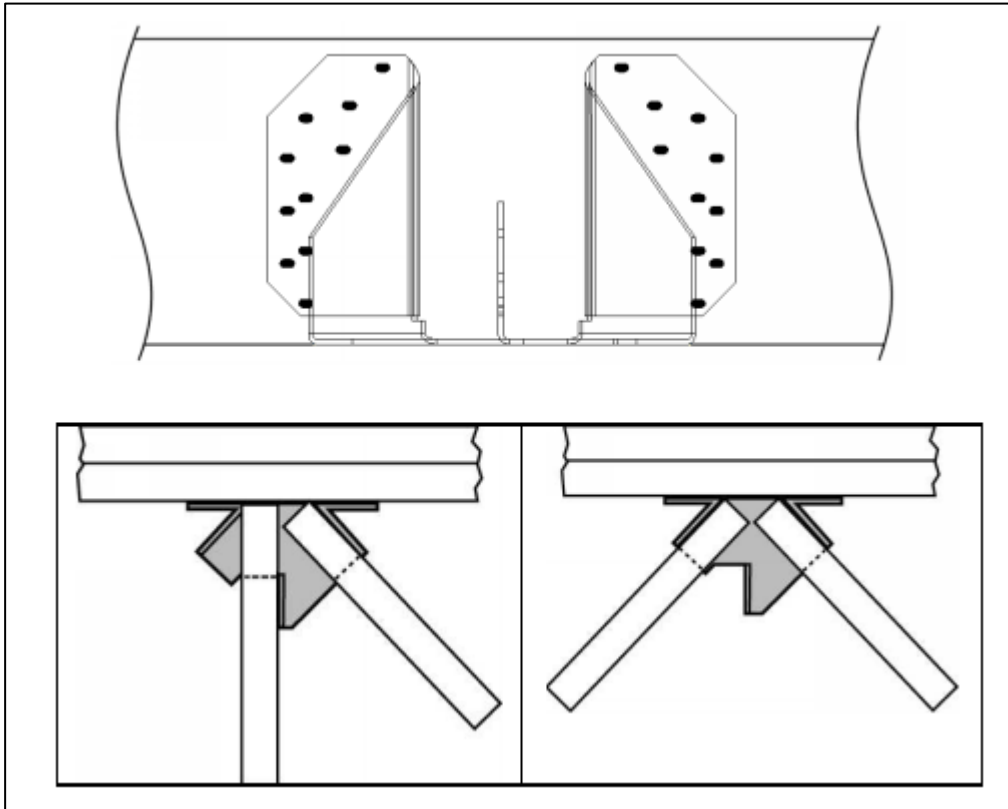

C11 THG Hangers

Header and Side Flanges

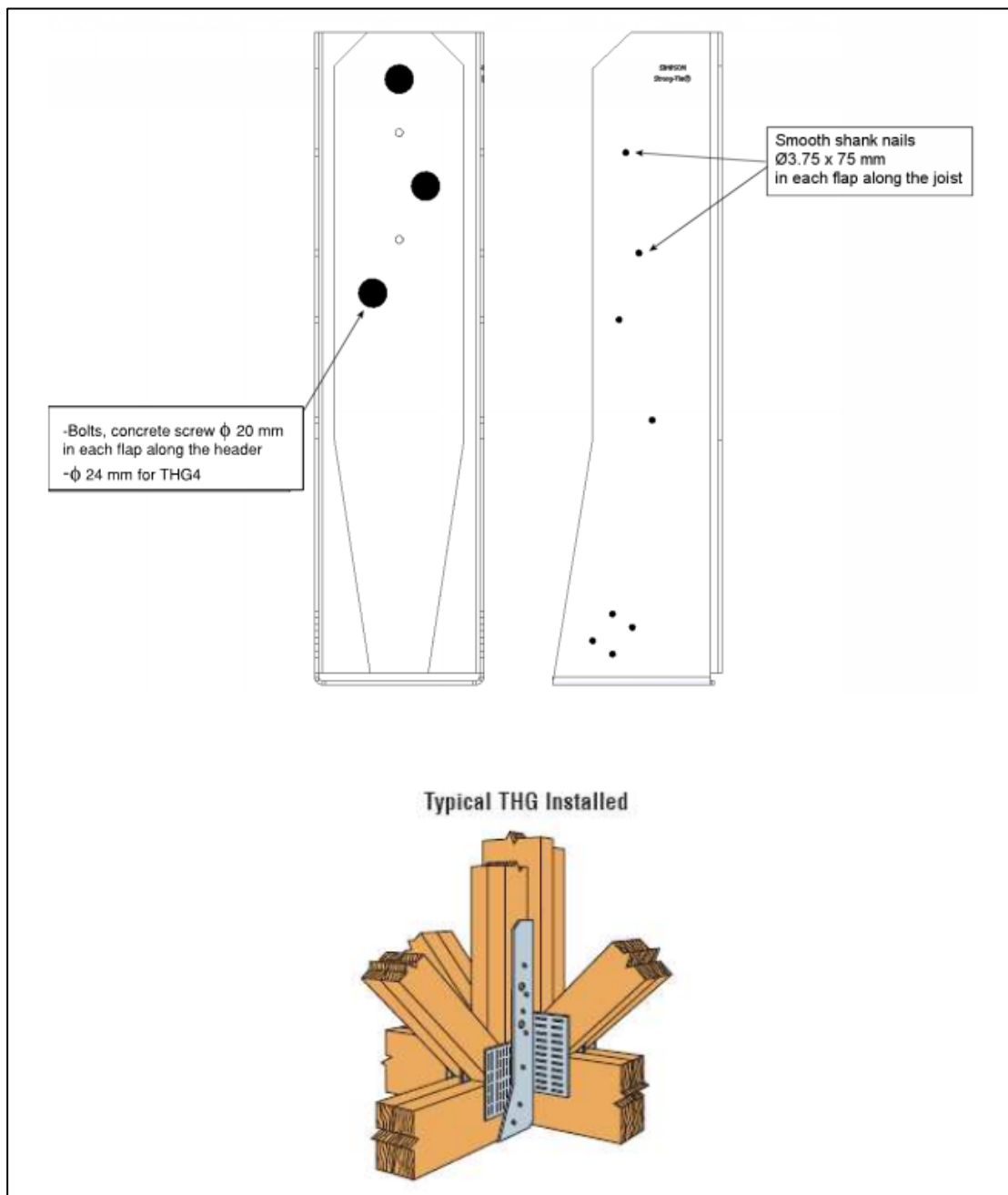

C12 THGQ Hangers

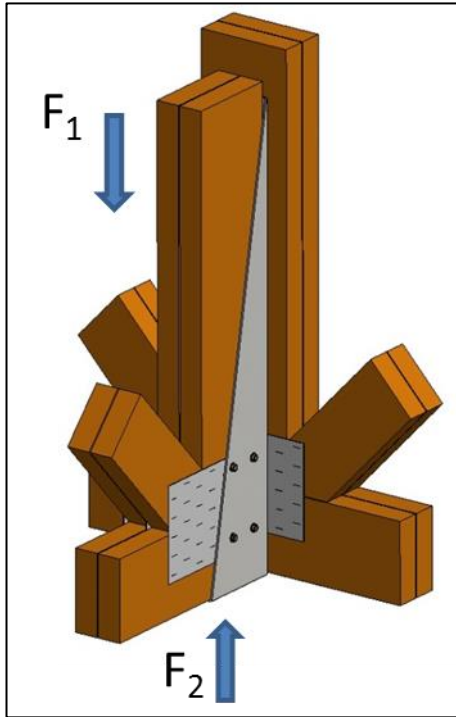

F1 – downward; F2 - uplift

The hangers shall only be used with the fasteners specified below.

Fastener Specification

Type	Diameter (mm)	Length (mm)
SDS	6.35	63

Annex D: Fastener Number & Characteristic Load-carrying Capacities

Fasteners

Unless specified otherwise, the fasteners in the tables below are CNA Ø4.0x35 mm nails as described in Annex B. Alternative fasteners may be used provided the instructions in Annex B are followed.

Density

The characteristic load bearing capacities given in tables below were all determined for timber materials with a characteristic density of 350 kg/m³ (C24), except for Table 20. Should a lower characteristic density be used, the load bearing capacity shall be amended accordingly:

$$F_k = F_{k,350} \times \left(\frac{\rho_k}{350} \right)^2$$

Where:

- ρ_k is the characteristic density of the timber or timber based material.
- F_k is the characteristic load bearing capacity for a timber material with a characteristic density ρ_k lower than 350 kg/m³.
- $F_{k, 350}$ is the characteristic load bearing capacity for a timber material with a characteristic density of 350 kg/m³ (characteristic values given in Annex D of this ETA).

For a characteristic density above 350 kg/m³ the values given in tables 10 to 15 should be used unchanged.

Table 11: ET Hangers - Load Carrying Capacities - Downward

Hangers	Number of Fasteners				Characteristic Capacities (kN) Downward
	Header Member		Carried Member		
	Concrete/Steel	Wood	Side Flange	Bottom Flange	
ET248	2 Bolts Ø10	14	3	3	8.75
ET260	2 Bolts Ø10	16	10	10	10.57
ET301	2 Bolts Ø10	16	10	10	11.28

Table 12: ET Hangers - Load Carrying Capacities – Uplift

Hangers	Min Header Depth (mm)	Number of Fastener			Characteristic Capacities (kN) Uplift
		Header Member Wood	Carried Member		
			Side Flange	Bottom Flange	
ET248	97	10	3	3	2.00
ET260	97	12	5	5	5.46
ET301	97	12	5	11	6.35

Table 13: ETC Hangers - Load Carrying Capacities - Downward

Hangers	Number of Fasteners							Characteristic Capacities (kN) Downward
	Header Member		Carried Member					
	Concrete/ Steel	Wood	Hip			Jack		
			Type	Side	Bottom	Side	Bottom	
ETC434	-	27	1 ply	3	3	3	3	5.5
ETC434	-	27	2 plys	3	4	3	3	5.5
ETC434	4 Bolts Ø12	57	1 ply	8	2	4	2	11.97
ETC434	4 Bolts Ø12	27	2 plys	8	3	4	2	16.82
ETC485	4 Bolts Ø12	24	2 plys	3	8	6	5	12.40
ETC835	4 Bolts Ø12	44	1 ply	8	10	-	5	21.29
ETC835	4 Bolts Ø12	44	2 plys	14	14	-	5	26.16

Note that a reduced number of fasteners in the header allows for a reduced header depth. The header depth should be ≥ 97 mm

Table 14: ETC Hangers - Load Carrying Capacities – Uplift

Hangers	Min. Header Depth (mm)	Number of Fasteners						Characteristic Capacities (kN) Uplift
		Header Member Wood	Carried Member					
			Hip			Jack		
			Type	Side	Bottom	Side	Bottom	
ETC434	97	16	1 ply	3	3	3	3	3.3
ETC434	97	16	2 plys	3	4	3	3	3.3
ETC485	97	14	2 plys	6	5	6	4	3.8
ETC835	250	40	2 plys	4	9	0	5	7.7

Note that fasteners in the horizontal back flanges of ETC434 and ETC835 do not contribute to the hanger's uplift resistance

Table 15: MTHM and MTHM-2 Hangers - Load Carrying Capacities - Downward

Hangers	Min. Header Depth (mm)	Number of Fasteners					Characteristic Capacities (kN) Downward
		Header Member	Carried Member				
			Hip		Jack		
			Type	Side	Type	Side	
Connection with 1 hip and 1 jack							
MTHM	147	34	1 No 1 ply 38mm width	8	38mm width	4	11.40
MTHM	222	42					15.62
MTHM-2	147	39	1 No 1 ply 38mm width	8	38mm width	4	15.54
MTHM-2	222	47					17.28
Connection with 2 hips and 1 jack							
MTHM	147	34	2 No 1 ply 38mm width	2 x 8	38mm width	4	17.66
MTHM	222	42					20.99
MTHM-2	147	39	2 No 1 ply 38mm width	2 x 8	38mm width	4	19.17
MTHM-2	222	47					23.07

Table 16: MTHM and MTHM-2 Hangers - Load Carrying Capacities - Uplift

Hangers	Min. Header Depth (mm)	Number of Fasteners					Characteristic Capacities (kN) Uplift
		Header Member	Carried Member				
			Hip		Jack		
			Type	Side	Type	Side	
Connection with 2 hips and 1 jack							
MTHM	222	42	2 No 1 ply 38mm width	2 x 8	38mm width	4	8.3
MTHM-2	222	47	2 No 1 ply 38mm width	2 x 8	38mm width	4	6.3

Table 17: THJA26 Hangers - Load Carrying Capacities - Downward

Hangers	Min. Header Depth (mm)	Number of Fasteners					Characteristic Capacities (kN) Downward
		Header Member	Carried Member				
			Hip		Jack		
			Type	Side	Type	Side	
Connection with 1 hip and 1 jack							
THJA26	147	20	1 No 1 ply 38mm width	6	38mm width	4	13.06
THJA26	175						13.15
Connection with 2 hips and 1 jack							
THJA26	147	20	2 No 1 ply 38mm width	2 x 6	-	4	13.67
THJA26	175						13.42

Table 18: THJA26 Hangers - Load Carrying Capacities - Uplift

Hangers	Min. Header Depth (mm)	Number of Fasteners					Characteristic Capacities (kN) Uplift
		Header Member	Carried Member				
			Hip		Jack		
			Type	Side	Type	Side	
Connection with 2 hips and 1 jack							
THJA26	175	20	2 No 1 ply 38mm width	2 x 6	-	4	5.8

Table 19: THG Hangers - Load Carrying Capacities - Timber Strength Class C24

Hanger	Fastener Number		Characteristic Capacity (kN)			
	Carrying Member (Bolts)	Carried Member (Nails)	Downward	Uplift		
				Ø4.0 x 35 (CNA)	Ø4.0 x 50 (CNA)	Ø3.75 x 75 (SS)
THG2	2 – 20 mm	14 No	27.92	24.92	27.49	22.82
THG3	3 – 20 mm	14 No	35.71	24.92	33.32	22.82
THG3B	3 – 20 mm	16 No	33.36	28.48	32.95	26.08
THG4	4 – 24 mm	18 No	48.64	32.04	42.84	29.34
THG4B (W=80)	4 – 20 mm	16 No	36.20	28.48	35.97	26.08
THG4B (W≥105)	4 – 20 mm	16 No	55.84	28.48	38.08	26.08

Table 20: THG Hangers - Load Carrying Capacities - Timber Strength Class C27

Hanger	Fastener Number		Characteristic Capacity (kN)			
	Carrying Member (Bolts)	Carried Member (Nails)	Downward	Uplift		
				Ø4.0 x 35 (CNA)	Ø4.0 x 50 (CNA)	Ø3.75 x 75 (SS)
THG2	2 – 20 mm	14 No	29.51	26.60	29.01	23.66
THG3	3 – 20 mm	14 No	37.75	26.60	35.14	23.66
THG3B	3 – 20 mm	16 No	35.27	30.40	34.78	27.04
THG4	4 – 24 mm	18 No	51.42	34.20	45.18	30.42
THG4B (W=80)	4 – 20 mm	16 No	38.27	30.40	38.00	27.04
THG4B (W≥105)	4 – 20 mm	16 No	59.03	30.40	40.16	27.04

Table 21: THGQ Hangers - Load Carrying Capacities – Downward - Timber Strength Class C27 / TR26

Hanger		Fastener Specification		Fastener Number		Characteristic Capacity (kN) Downward
Code	Width (mm)	Type	Size (mm)	Carrying Member	Carried Member	
THGQ	80 - 116	SDS	6.35 × 63	30	4	66.3
THGQ	80 - 116	SDS	6.35 × 63	30	8	79.7
THGQ	154 - 202	SDS	6.35 × 63	32	4	66.3
THGQ	154 - 202	SDS	6.35 × 63	32	8	79.7

Table 22: THGQ Hangers - Load Carrying Capacities – Uplift - Timber Strength Class C27 / TR26

Hanger		Fastener Specification		Fastener Number		Characteristic Capacity (kN) Uplift
Code	Width (mm)	Type	Size (mm)	Carrying Member	Carried Member	
THGQ	80 - 116	SDS	6.35 × 63	30	4	11.2
THGQ	80 - 116	SDS	6.35 × 63	30	8	22.4
THGQ	154 - 202	SDS	6.35 × 63	32	4	11.2
THGQ	154 - 202	SDS	6.35 × 63	32	8	22.4